



T-75-37-05

UM82450

Asynchronous Communication Element (ACE)

Features

- Adds or deletes standard asynchronous communication bits (start, stop, and parity) to or from a serial data stream
- Full double buffering eliminates the need for precise synchronization
- Independently controlled transmit, receive, line status, and data set interrupts
- Programmable baud rate generator allows division of any input clock by 1 to $2^{16}-1$ and generates the internal 16x clock
- Independent receiver clock input
- Modem control functions (CTS, RTS, DSR, DTR, RI, and DCD)
- Single +5 volt power supply
- TRI-STATE TTL Drive capabilities for bidirectional

data bus and control bus.

- Fully programmable serial-interface characteristics
 - 5-, 6-, 7-, or 8-bit characters
 - Even, odd, or no-parity bit generation and detection
 - 1-, 1½-, or 2-stop bit generation
 - Baud rate generation (DC to 56k baud)
- False start bit detection *82450*
- Complete status reporting capabilities
- Easily interfaces to most popular microprocessors
- Line break generation and detection
- Internal diagnostic capabilities
 - Loopback controls for communications link fault isolation
 - Break, parity, overrun, framing error simulation
- Fully prioritized interrupt system controls

General Description

UM82450 is a programmable Asynchronous Communication Element (ACE) chip fabricated using the Si-Gate NMOS process. The UM82450 is an improved version of the UM8250. It performs serial-to-parallel conversion on data characters received from a peripheral device or a modem, and parallel-to-serial conversion on data characters received from the CPU. The CPU can read

the complete status of the ACE at any time during functional operation. It also includes a programmable baud rate generator that is capable of dividing the timing reference clock input by divisors of 1 to $2^{16}-1$, and producing a 16x clock for driving the internal transmitter logic.

Pin Configurations

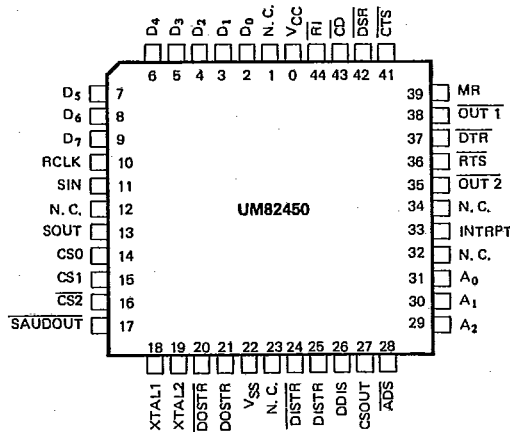
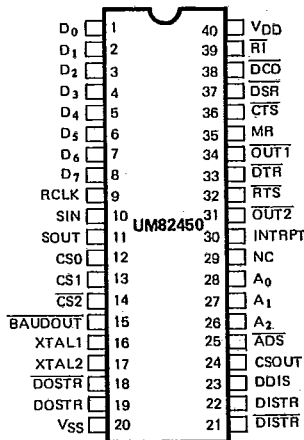



Block Diagram

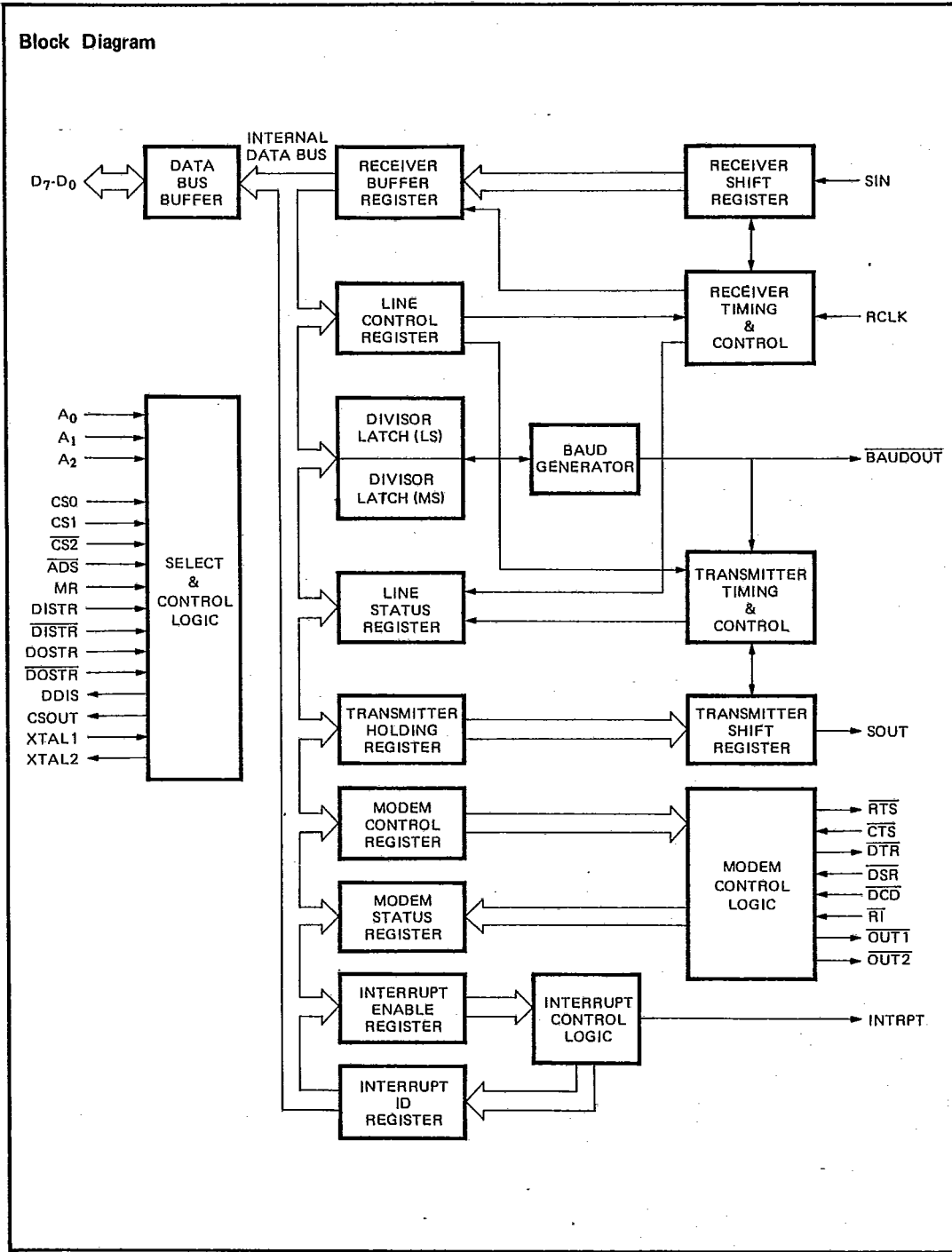

I/O And
Peripherals



T-75-37-05

UM82450

Absolute Maximum Ratings*

Temperature Under Bias 0°C to +70°C
 Storage Temperature -65°C to +150°C
 All Input or Output Voltages with
 Respect to V_{SS} -0.5V to +7.0V
 Power Dissipation 700 mW

***Comments**

Stresses above those listed under "Absolute Maximum Ratings" may cause permanent damage to the device. These are stress ratings only. Functional operation of this device at these or any other conditions above those indicated in the operational sections of this specification is not implied and exposure to absolute maximum rating conditions for extended periods may affect device reliability.

DC Electrical Characteristics

T_A = 0°C to +70°C, V_{DD} = +5V ± 5%, V_{SS} = 0V, unless otherwise specified.

Symbol	Parameter	Conditions	Min.	Max.	Units
V _{ILX}	Clock Input Low Voltage		-0.5	0.8	V
V _{IHX}	Clock Input High Voltage		2.0	V _{CC}	V
V _{IL}	Input Low Voltage		-0.5	0.8	V
V _{IH}	Input High Voltage		2.0	V _{CC}	V
V _{OL}	Output Low Voltage	I _{OL} = 1.6 mA on all*		0.4	V
V _{OH}	Output High Voltage	I _{OL} = -1.0 mA*	2.4		V
I _{CC (AV)}	Avg Power Supply Current (V _{CC})	V _{CC} = 5.25V, T _A = 25°C No Loads on output SIN, DSR, RLSD, CTS, RI = 2.0V All other inputs = 0.8V		120	mA
I _{IL}	Input Leakage	V _{CC} = 5.25V, V _{SS} = 0V All other pins floating.		±10	µA
I _{CL}	Clock Leakage	V _{IN} = 0V, 5.25V		±10	µA
I _{OZ}	TRI-STATE Leakage	V _{CC} = 5.25V, V _{SS} = 0V V _{OUT} = 0V, 5.25V 1) Chip deselected 2) WRITE Mode, chip selected		±20	µA
V _{ILMR}	MR Schmitt V _{IL}			0.8	V
V _{IHMR}	MR Schmitt V _{IH}		2.0		V

* Does not apply to XTAL2

Capacitance

T_A = 25°C, V_{CC} = V_{SS} = 0V

Symbol	Parameter	Conditions	Min.	Typ.	Max.	Units
C _{XTAL2}	Clock Input Capacitance	f _c = 1 MHz Unmeasured pins returned to V _{SS}		15	20	pF
C _{XTAL1}	Clock Output Capacitance			20	30	pF
C _{IN}	Input Capacitance			6	10	pF
C _{OUT}	Output Capacitance			10	20	pF



T-75-37-05

UM82450

AC Characteristics

T_A = 0°C to 70°C, V_{DD} = +5V ± 5%

Symbol	Parameter	Conditions	Min.	Max.	Units
t _{AW}	Address Strobe Width		60	—	ns
t _{AS}	Address Setup Time		60		ns
t _{AH}	Address Hold Time		0		ns
t _{CS}	Chip Select Setup Time		60		ns
t _{CH}	Chip Select Hold Time		0		ns
t _{DIW}	DISTR/DISTR Strobe Width		125		ns
t _{RC}	Read Cycle Delay		175		ns
RC	Read Cycle = t _{AR} * + t _{DIW} + t _{RC}		360		ns
t _{DD}	DISTR/DISTR to Driver Disable Delay	@100 pF loading***		60	ns
t _{DDD}	Delay from DISTR/DISTR to Data	@100 pF loading		125	ns
t _{HZ}	DISTR/DISTR to Floating Data Delay	@100 pF loading***	0	100	ns
t _{DOW}	DOSTR/DOSTR Strobe Width		100		ns
t _{WC}	Write Cycle Delay		200		ns
WC	Write Cycle = t _{AW} + t _{DOW} + t _{WC}		360		ns
t _{DS}	Data Setup Time		40		ns
t _{DH}	Data Hold Time		40		ns
t _{CSC} *	Chip Select Output Delay from Select	@100 pF loading		100	ns
t _{RA} *	Address Hold Time from DISTR/DISTR		20		ns
t _{RCS} *	Chip Select Hold Time from DISTR/DISTR		20		ns
t _{AR} *	DISTR/DISTR Delay from Address		60		ns
t _{CSR} *	DISTR/DISTR Delay from Chip Select		50		ns
t _{WA} *	Address Hold Time from DOSTR/DOSTR		20		ns
t _{WCS} *	Chip Select Hold Time from DOSTR/DOSTR		20		ns
t _{AW} *	DOSTR/DOSTR Delay from Address		60		ns
t _{CSW} *	DOSTR/DOSTR Delay from Select		50		ns
t _{MRW}	Master Reset Pulse Width		5		ns
t _{XH}	Duration of Clock High Pulse	External Clock (3.1 MHz Max.)	140		μs
t _{XL}	Duration of Clock Low Pulse	External Clock (3.1 MHz Max.)	140		ns
Baud Generator					
N	Baud Divisor		1	2 ¹⁶ -1	
t _{BLD}	Baud Output Negative Edge Delay	100 pF Load		125	ns
t _{BHD}	Baud Output Positive Edge Delay	100 pF Load		125	ns
t _{LW}	Baud Output Down Time	f _x = 2MHz, ÷ 2, 100 pF Load	425		ns
t _{HW}	Baud Output Up Time	f _x = 3MHz, ÷ 3, 100 pF Load	330		ns
Receiver					
t _{SCD}	Delay from RCLK to Sample Time			2	μs
t _{SINT}	Delay from Stop to Set Interrupt		1	1	RCLK** Cycles
t _{RINT}	Delay from DISTR/DISTR (RD RBR/RDLSR) to Reset Interrupt	100 pF Load		1	μs
<p>*Applicable only when \overline{ADS} is tied low. **RCLK is equal to t_{XH} and t_{XL}. ***Charge and discharge time is determined by V_{OL}, V_{OH} and the external loading.</p>					

I/O And Peripherals



T-75-37-05

A.C. Characteristics (Continued)

Symbol	Parameter	Conditions	Min.	Max.	Units
Transmitter					
t _{HR}	Delay from $\overline{\text{DOSTR}}/\text{DOSTR}$ (WR THR) to Reset Interrupt	100 pF Load		175	ns
t _{IRS}	Delay from Initial INTR Reset to Transmit Start		8	24	RCLK Cycles
t _{SI}	Delay from Initial Write to Interrupt		16	32	RCLK Cycles
t _{STI}	Delay from Stop to Interrupt (THRE)		8	8	RCLK Cycles
t _{IR}	Delay from $\overline{\text{DISTR}}/\text{DISTR}$ (RD IIR) to Reset Interrupt (THRE)	100 pF Load		250	ns
Modem Control					
t _{MDO}	Delay from $\overline{\text{DOSTR}}/\text{DOSTR}$ (WR MCR) to Output	100 pF Load		200	ns
t _{SIM}	Delay to Set Interrupt from MODEM Input	100 pF Load			ns
t _{TRIM}	Delay to Reset Interrupt from $\overline{\text{DISTR}}/\text{DISTR}$ (RD MSR)	100 pF Load		250	ns

Timing Waveforms

EXTERNAL CLOCK INPUT (3.1 MHz MAX.)

AC TEST POINTS

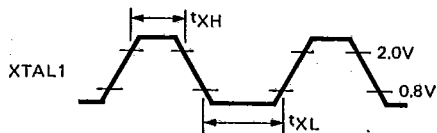

BAUDOUT TIMING

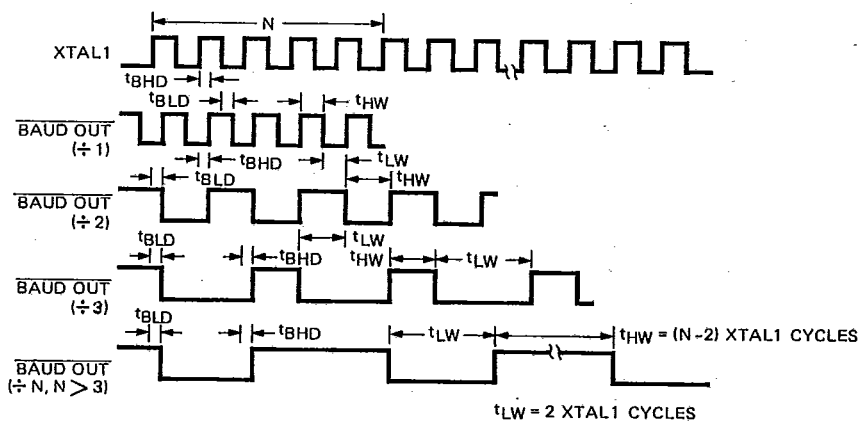



T-75-37-05

UM82450

Timing Waveforms (Continued)

WRITE CYCLE

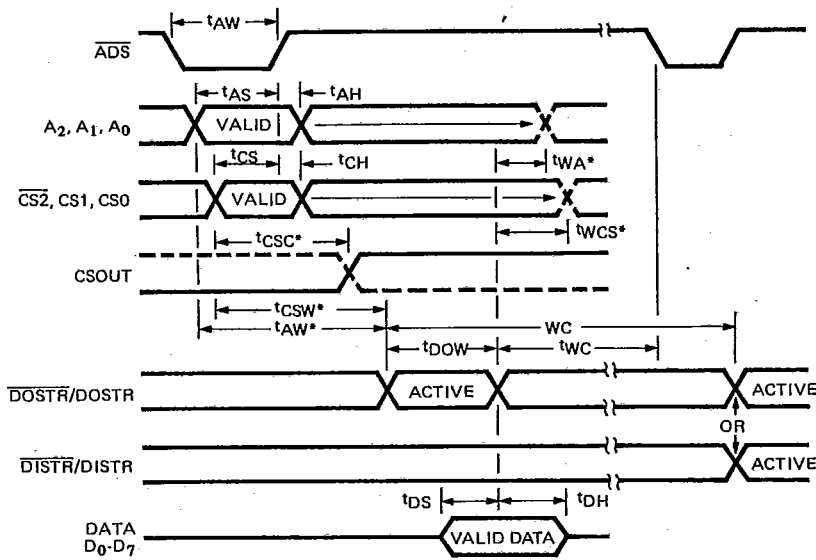

*Applicable Only When \overline{ADS} is Tied Low.

READ CYCLE

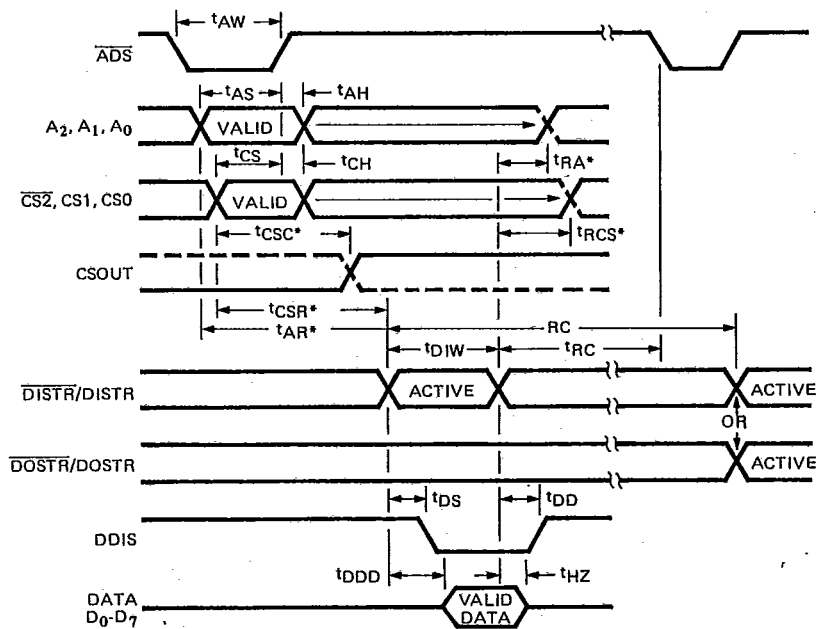

*Applicable Only When \overline{ADS} is Tied Low.

I/O And Peripherals



T-75-37-05

UM82450

Timing Waveforms (Continued)

RECEIVER TIMING

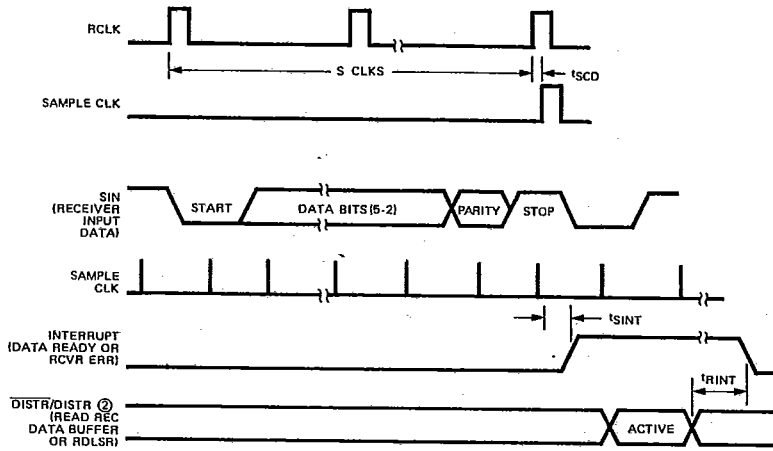

TRANSMITTER TIMING

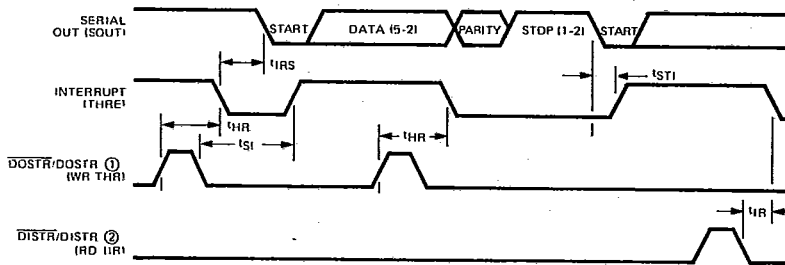

MODEM CONTROL TIMING

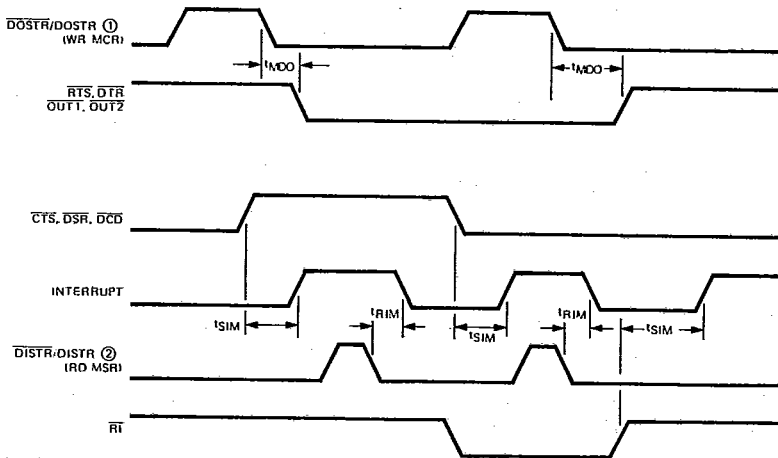

Note: 1. See Write Cycle Timing
2. See Read Cycle Timing



Pin Description

Input Signals

Chip Select (CS0, CS1, CS2), Pins 12-14: When CS0 and CS1 are high and CS2 is low, the chip is selected. Chip selection is complete when the decoded chip select signal is latched with an active (low) Address Strobe (ADS) input. This enables communication between the ACE and the CPU.

Data Input Strobe (DISTR, DISTR), Pins 22 and 21: When DISTR is high or DISTR is low while the chip is selected, it allows the CPU to read status information or data from a selected register of the ACE. Only an active DISTR or DISTR input is required to transfer data from the ACE during a read operation. Therefore, tie either the DISTR input permanently low or the DISTR Input permanently high, if not used.

Data Output Strobe (DOSTR, DOSTR), Pins 19 and 18: The DOSTR is high or DOSTR is low while the chip is selected, which allows the CPU to write data or control words into a selected register of the ACE. Only an active DOSTR or DOSTR input is required to transfer data to the ACE during a write operation. Therefore, tie either the DOSTR input permanently low or the DOSTR input permanently high, if not used.

Address Strobe (ADS), Pin 25: When this is low, it provides latching for the Register Select (A0, A1, A2) and Chip Select (CS0, CS1, CS2) signals. An active ADS input is required when the Register Select (A0, A1, A2) signals are not stable for the duration of a read or write operation. If not required, tie the ADS input permanently low.

Register Select (A2, A1, A0), Pins 26-28: These three inputs are used during a read or write operation to select an ACE register to read from or write to as indicated in Table 1. The DLAB must be set high by the system software to access the Baud Generator Divisor Latches.

Master Reset (MR), Pin 35: This input is buffered with a TTL-compatible Schmitt Trigger with 0.5V typical hysteresis. When high, it clears all the registers (except the Receiver Buffer, Transmitter Holding, and Divisor Latches), and the control logic of the ACE. Also, the state of various output signals (SOUT, INTRPT, OUT 1, OUT 2, RTS, DTR) are affected by an active MR input. (Refer to Table 2)

Receiver Clock (RCLK), Pin 9: This input is the 16 x baud rate clock for the receiver section of the chip.

Serial Input (SIN), Pin 10: Serial data input from the communications link (peripheral device, MODEM, or data set).

Clear to Send (CTS), Pin 36: The CTS signal is a MODEM control function input whose conditions can be tested

by the CPU by reading bit 4 (CTS) of the MODEM Status Register. Bit 0 (DCTS) of the MODEM Status Register indicates whether the CTS input has changed state since the previous reading of the MODEM Status Register. CTS has no effect on the Transmitter. Whenever the CTS bit of the MODEM Status Register changes state, an interrupt is generated if the MODEM Status Interrupt is enabled.

DLAB	A ₂	A ₁	A ₀	Register
0	0	0	0	Receiver Buffer (read), Transmitter Holding Register (write)
0	0	0	1	Interrupt Enable
X	0	1	0	Interrupt Identification (read only)
X	0	1	1	Line Control
X	1	0	0	MODEM Control
X	1	0	1	Line Status
X	1	1	0	MODEM Status
X	1	1	1	Scratch
1	0	0	0	Divisor Latch (least significant byte)
1	0	0	1	Divisor Latch (most significant byte)

Table 1. Register address

Data Set Ready (DSR), Pin 37: When low, this indicates that the MODEM or data set is ready to establish the communications link and transfer data with the ACE. The DSR signal is a MODEM-control function input whose condition can be tested by the CPU by reading bit 5 (DSR) of the MODEM Status Register. Bit 1 (DDSR) of the MODEM Status Register indicates whether the DSR input has changed state since the previous reading of the MODEM Status Register. Whenever the DSR bit of the MODEM Status Register changes state, an interrupt is generated if the MODEM Status Interrupt is enabled.

Data Carrier Detect (DCD), Pin 38: When low, this indicates that the data carrier has been detected by the MODEM or data set. The DCD signal is a MODE-control function input whose condition can be tested by the CPU by reading bit 7 (DCD) of the MODEM Status Register. Bit 3 (DDCD) of the MODEM Status Register indicates whether the DCD input has changed state since the previous reading of the MODEM Status Register. DCD has no effect on the receiver. Whenever the DCD bit of the MODEM Status Register changes state, an interrupt is generated if the MODEM Status Interrupt is enabled.

Ring Indicator (RI), Pin 39: When low, it indicates that a telephone ringing signal has been received by the MODEM or data set. The RI signal is a MODEM-control function input whose condition can be tested by the CPU by reading bit 6 (RI) of the MODEM Status Register. Bit 2 (TERI)

IO And Peripherals

T-75-37-05



UM82450

of the MODEM Status Register indicates whether the \overline{RI} input has changed from a low to a high state since the previous reading of the MODEM Status Register. Whenever the RI bit of the MODEM Status Register changes from a high to a low state, an interrupt is generated if the MODEM Status Register is enabled.

V_{DD} , Pin 40: +5V supply.

V_{SS} , Pin 20: Ground (0V) reference.

Output Signals

Data Terminal Ready (\overline{DTR}), Pin 33: When low, this informs the MODEM or data set that the ACE is ready to communicate. The DTR output signal can be set to an active low by programming bit 0 (DTR) of the MODEM Control Register to a high level. The DTR signal is set high upon a Master Reset operation. The DTR signal is forced to its inactive state (high) during loop mode operation.

Request to Send (\overline{RTS}), Pin 32: When low, this informs the MODEM or data set that the ACE is ready to transmit data. The \overline{RTS} output signal can be set to an active low by programming bit 1 (RTS) of the MODEM Control Register. The \overline{RTS} signal is set high upon a Master Reset operation. The \overline{RTS} signal is forced to its inactive state (high) during loop mode operation.

Output 1 ($\overline{OUT 1}$), Pin 34: This is a User-designated output that can be set to an active low by programming bit 2 (OUT 1) of the MODEM Control Register to a high level. The $\overline{OUT 1}$ signal is set high upon a Master Reset Operation. The $\overline{OUT 1}$ signal is forced to its inactive state (high) during loop mode operation.

Output 2 ($\overline{OUT 2}$), Pin 31: This is a User-designated output that can be set to an active low by programming bit 3 (OUT 2) of the MODEM Control Register to a high level. The $\overline{OUT 2}$ signal is set high upon a Master Reset Operation. The $\overline{OUT 2}$ signal is forced to its inactive state (high) during loop mode operation.

Chip Select Out (CSOUT), Pin 24: When high, indicates that the chip has been selected by active, CS0, CS1, and CS2 inputs. No data transfer can be initiated until the CSOUT signal is a logic 1. CSOUT goes low when the chip is deselected.

Driver Disable (DDIS), Pin 23: This goes low whenever the CPU is reading data from the ACE. A high-level DDIS output can be used to disable an external transceiver (if used between the CPU and ACE on the D_7-D_0 Data Bus) at all times, except when the CPU is reading data.

Baud Out ($\overline{BAUDOUT}$), Pin 15: This is a 16x clock signal for the transmitter section of the ACE. The clock rate is equal to the main reference oscillator frequency divided by the specified divisor in the Baud Generator Divisor Latches.

The $\overline{BAUDOUT}$ may also be used for the receiver section by tying this output to the RCLK input of the chip.

Interrupt (INTRPT), Pin 30: Goes high whenever any one of the following interrupt types has an active high condition and is enabled via the IER: Receiver Error Flag; Received Data Available; Transmitter Holding Register Empty and MODEM Status. The INTRPT signal is reset low upon the appropriate interrupt service or a Master Reset operation.

Serial Output (SOUT), Pin 11: Composite serial data output to the communications link (peripheral, MODEM or data set). The SOUT signal is set to the Marking (logic 1) state upon a Master Reset operation.

Input/Output Signals

Data (D_7-D_0) Bus, Pins 1-8: This bus comprises eight TRI-STATE input/output lines. The bus provides bidirectional communications between the ACE and the CPU. Data, control words and status information are transferred via the D_7-D_0 Data Bus.

External Clock Input/Output (XTAL 1, XTAL 2), Pins 16 and 17: These two pins connect the main timing reference (crystal or signal clock) to the ACE.

Programmable Registers

The system programmer may access or control any of the ACE registers summarized in Table 3 via the CPU. These registers are used to control ACE operations and to transmit and receive data.

Line Control Register

The system programmer specifies the format of the asynchronous data communications exchange via the Line Control Register. In addition to controlling the format, the programmer may retrieve the contents of the Line Control Register for inspection. This feature simplifies system programming and eliminates the need for separate storage in system memory of the line characteristics. The contents of the Line Control Register are indicated in Table 3 and are described below.

Bits 0 and 1: These two bits specify the number of bits in each transmitted or received serial character. The encoding of bits 0 and 1 is as follows:

Bit 1	Bit 0	Word Length
0	0	5 Bits
0	1	6 Bits
1	0	7 Bits
1	1	8 Bits



UM82450

Bit 2: This bit specifies the number of Stop bits in each transmitted character. If bit 2 is a logic 0, one Stop bit is generated in the transmitted data. If bit 2 is a logic 1 when a 5-bit word length is selected via bits 0 and 1, one and a half Stop bits are generated. If bit 2 is a logic 1 when either a 6-, 7-, or 8-bit word length is selected, two Stop bits are generated. The Receiver checks the first Stop-bit only, regardless of the number of Stop bits selected.

Bit 3: This bit is the Parity Enable bit. When bit 3 is a logic 1, a Parity bit is generated (transmit data) or checked (receive data) between the last data word bit and Stop bit of the serial data. (The Parity bit is used to produce an even or odd number of 1s when the data word bits and the Parity bit are summed.)

Bit 4: This bit is the Even Parity Select bit. When bit 3 is a logic 1 and bit 4 is a logic 0, an odd number of logic 1s is transmitted or checked in the data word bits and Parity bit. When bit 3 is a logic 1 and bit 4 is a logic 1, an even number of logic 1s is transmitted or checked.

Bit 5: This bit is the Stick Parity bit. When bits 3, 4 and 5 are logic 1s the Parity bit is transmitted and checked by the receiver as a logic 0. If bits 3 and 5 are 1s and bit 4 is a logic 0 then the Parity bit is transmitted as a 0.

Bit 6: This bit is the Break Control bit. When it is set to a logic 1, the serial output (SOUT) is forced to the Spacing (logic 0) state. The break is disabled by setting bit 6 to a logic 0. The Break Control bit acts only on SOUT and has no effect on the transmitter logic.

Note: This feature enables the CPU to alert a terminal in a computer communications system. If the following sequence is followed, no erroneous or extraneous characters will be transmitted because of the break.

1. Load an all 0s, pad character, in response to THRE.
2. Set break after the next THRE.
3. Wait for the transmitter to be idle, (TEMT = 1), and clear the break when normal transmission has been restored.

During the break, the Transmitter can be used as a character timer to accurately establish the break duration.

Bit 7: This bit is the Divisor Latch Access Bit (DLAB). It must be set high (logic 1) to access the Divisor Latches of the Baud Generator during a Read or Write operation. It must be set low (logic 0) to access the Receiver Buffer, the Transmitter Holding Register, or the Interrupt Enable Register.

Table 2. ACE Reset Functions

Register/Signal	Reset Control	Reset State
Interrupt Enable Register	Master Reset	All Bits Low (0 - 3 forced and 4 - 7 permanent)
Interrupt Identification Register	Master Reset	Bit 0 is High, Bits 1 and 2 Low Bits 3 - 7 are Permanently Low
Line Control Register	Master Reset	All Bits Low
MODEM Control Register	Master Reset	All Bits Low
Line Status Register	Master Reset	All Bits Low, Except Bits 5 & 6 are High
MODEM Status Register	Master Reset	Bits 0 - 3 Low Bits 4 - 7 - Input Signal
SOUT	Master Reset	High
INTRPT (RCVR Errs)	Read LSR/MR	Low
INTRPT (RCVR Data Ready)	Read RBR/MR	Low
INTRPT (THRE)	Read IIR/Write THR/MR	Low
INTRPT (Modem Status Changes)	Read MSR/MR	Low
$\overline{\text{OUT 2}}$	Master Reset	High
$\overline{\text{RTS}}$	Master Reset	High
$\overline{\text{DTR}}$	Master Reset	High
$\overline{\text{OUT 1}}$	Master Reset	High

I/O And Peripherals



T-75-37-05

UM82450

Table 3. Summary of Accessible Registers

Bit No.	Register Address										
	0 DLAB=0	0 DLAB=0	1 DLAB=0	2	3	4	5	6	7	0 DLAB=1	1 DLAB=1
	Receiver Buffer Register (Read Only)	Transmitter Holding Register (Write Only)	Interrupt Enable Register	Interrupt Ident. Register (Read Only)	Line Control Register	MODEM Control Register	Line Status Register	MODEM Status Register	Scratch Register	Divisor Latch (LS)	Divisor Latch (MS)
	RBR	THR	IER	IIR	LCR	MCR	LSR	MSR	SCR	DLL	DLM
0	Data Bit 0*	Data Bit 0	Enable Received Data Available Interrupt (ERBFI)	"0" if Interrupt Pending	Word Length Select Bit 0 (WLS0)	Data Terminal Ready (DTR)	Data Ready (DR)	Delta Clear to Send (DCTS)	Bit 0	Bit 0	Bit 8
1	Data Bit 1	Data Bit 1	Enable Transmitter Holding Register Empty Interrupt (ETBEI)	Interrupt ID Bit (0)	(WL) Word Length Select Bit 1 (WLS1)	Request to Send (RTS)	Overrun Error (OR)	Delta Data Set Ready (DDSR)	Bit 1	Bit 1	Bit 9
2	Data Bit 2	Data Bit 2	Enable Receiver Line Status Interrupt (ELSI)	Interrupt ID Bit (1)	Number of Stop Bits (STB)	Out 1	Parity Error (PE)	Trailing Edge Ring Indicator (TERI)	Bit 2	Bit 2	Bit 10
3	Data Bit 3	Data Bit 3	Enable MODEM Status Interrupt (EDSSI)	0	Parity Enable (PEN)	Out 2	Framing Error (FE)	Delta Data Carrier Detect (DDCD)	Bit 3	Bit 3	Bit 11
4	Data Bit 4	Data Bit 4	0	0	Even Parity Select (EPS)	Loop	Break Interrupt (BI)	Clear to Send (CTS)	Bit 4	Bit 4	Bit 12
5	Data Bit 5	Data Bit 5	0	0	Stick Parity	0	Transmitter Holding Register (THRE)	Data Set Ready (DSR)	Bit 5	Bit 5	Bit 13
6	Data Bit 6	Data Bit 6	0	0	Set Break	0	Transmitter Empty (TEMT)	Ring Indicator (RI)	Bit 6	Bit 6	Bit 14
7	Data Bit 7	Data Bit 7	0	0	Divisor Latch Access Bit (DLAB)	0	0	Data Carrier Detect (DCD)	Bit 7	Bit 7	Bit 15

* Bit 0 is the least significant bit. It is the first bit serially transmitted or received.



T-75-37-05
UM82450

Programmable Baud Generator

The ACE contains a programmable Baud Generator that is capable of taking any clock input (DC to 3.1 MHz) and dividing it by any divisor from 1 to $2^{16}-1$. The output frequency of the Baud Generator is $16 \times$ the Baud [divisor # = (frequency input) \div (baud rate \times 16)]. Two 8-bit latches store the divisor in a 16-bit binary format. These Divisor Latches must be loaded during initialization in order to ensure desired operation of the Baud Generator. Upon loading either of the Divisor Latches, a 16-bit Baud counter is immediately loaded. This prevents long counts on initial load.

Tables 4 and 5 illustrate the use of the Baud Generator with crystal frequencies of 1.8432 MHz and 3.072 MHz respectively. For baud rates of 38400 and below, the error obtained is minimal. The accuracy of the desired baud rate is dependent on the crystal frequency chosen. The maximum operating frequency of the Baud Generator is 3.1 MHz. However, when using divisors of 3 and below, the maximum frequency is equal to the divisor in MHz. For example, if the divisor is 1, then the maximum frequency is 1 MHz. In no case should the data rate be greater than 56k Baud.

Table 4. Baud Rates Using a 1.8432 MHz Crystal

Desired Baud Rate	Divisor Used to Generate 16 x Clock	Percent Error Difference Between Desired and Actual
50	2304	—
75	1536	—
110	1047	0.026
134.5	857	0.058
150	768	—
300	384	—
600	192	—
1200	96	—
1800	64	—
2000	58	0.69
2400	48	—
3600	32	—
4800	24	—
7200	16	—
9600	12	—
19200	6	—
38400	3	—
56000	2	2.86

Line Status Register

This 8-bit register provides status information to the CPU concerning the data transfer. The contents of the Line Status Register are indicated in Table 3 and are described below.

Bit 0: This bit is the receiver Data Ready (DR) indicator. Bit 0 is set to a logic 1 whenever a complete incoming character has been received and transferred into the Receiver Buffer Register. Bit 0 is reset to a logic 0 by reading the data in the Receiver Buffer Register.

Bit 1: This bit is the Overrun Error (OE) indicator. Bit 1 indicates that data in the Receiver Buffer Register was not read by the CPU before the next character was transferred into the Receiver Buffer Register, thereby destroying the previous character. The OE indicator is reset whenever the CPU reads the contents of the Line Status Register.

Bit 2: This bit is the Parity Error (PE) indicator. Bit 2 indicates that the received data character does not have the correct even or odd parity, as selected by the even-parity-select bit. The PE bit is set to a logic 1 upon detection of a parity error and is reset to a logic 0 whenever the CPU reads the contents of the Line Status Register.

Bit 3: This bit is the Framing Error (FE) indicator. Bit 3 indicates that the received character did not have a valid Stop bit. Bit 3 is set to a logic 1 whenever the Stop bit following the last data bit or parity bit is detected as a zero bit (Spacing level). The FE indicator is reset whenever the CPU reads the contents of the Line Status indicator.

Typical Oscillator Application

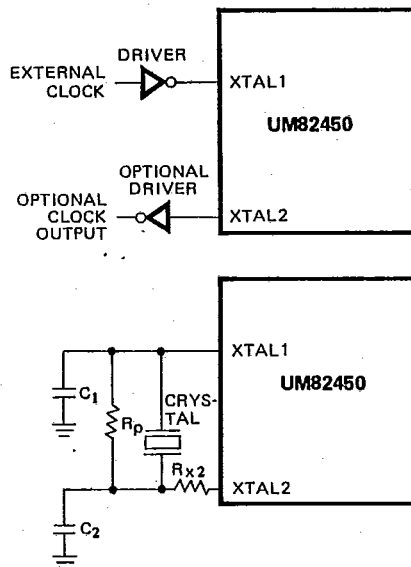

I/O And Peripherals

Typical Crystal Oscillator Network

Crystal	R _p	R _{x2}	C ₁	C ₂
3.1 MHz	1 MΩ	1.5K	10-30 pF	40-60 pF
1.8 MHz	1 MΩ	1.5K	10-30 pF	40-60 pF



T-75-37-05

UM82450

Table 5. Baud Rates Using 3.072MHz Crystal

Desired Baud Rate	Divisor Used to Generate 16 x Clock	Percent Error Difference Between Desired and Actual
50	3840	—
75	2560	—
110	1745	0.026
134.5	1428	0.034
150	1280	—
300	640	—
600	320	—
1200	160	—
1800	107	0.312
2000	96	—
2400	80	—
3600	53	0.628
4800	40	—
7200	27	1.23
9600	20	—
19200	10	—
38400	5	—

Bit 4: This bit is the Break Interrupt (BI) indicator. Bit 4 is set to a logic 1 whenever the received data input is held in the Spacing (logic 0) state for longer than a full word transmission time (that is, the total time of Start bit + data bits + Parity + Stop bits). The BI indicator is reset whenever the CPU reads the contents of the Line Status indicator. Bits 1 through 4 are the error conditions that produce a Receiver Line Status interrupt whenever any of the corresponding conditions are detected.

Bit 5: This bit is the Transmitter Holding Register Empty (THRE) indicator. Bit 5 indicates that the ACE is ready to accept a new character for transmission. In addition, this bit causes the ACE to issue an interrupt to the CPU when the Transmit Holding Register Empty Interrupt enable is set high. The THRE bit is set to a logic 1 when a character is transferred from the Transmitter Holding Register into the Transmitter Shift Register. The bit is reset to logic 0 concurrently with the loading of the Transmitter Holding Register by the CPU.

Bit 6: This bit is the Transmitter Empty (TEMT) indicator. Bit 6 is set to a logic 1 whenever the Transmitter Holding Register (THR) and the Transmitter Shift Register (TSR) are both empty. It is reset to a logic 0 whenever either the THR or TSR contains a data character.

Table 6. Interrupt Control Functions

Interrupt Identification Register			Interrupt Set and Reset Functions			
Bit 2	Bit 1	Bit 0	Priority Level	Interrupt Type	Interrupt Source	Interrupt Reset Control
0	0	1	—	None	None	—
1	1	0	Highest	Receiver Line Status	Overrun Error or Parity Error or Framing Error or Break Interrupt	Reading the Line Status Register
1	0	0	Second	Receive Data Available	Receiver Data Available	Reading the Receiver Buffer Register
0	1	0	Third	Transmitter Holding Register Empty	Transmitter Holding Register Empty	Reading the IIR Register (if source of interrupt) or Writing into the Transmitter Holding Register
0	0	0	Fourth	MODEM Status	Clear to Send or Data Set Ready or Ring Indicator or Data Carrier Detect	Reading the MODEM Status Register



T-75-37-05

UM82450

Bit 7: This bit is permanently set to logic 0. The Line Status Register is intended for read operations only. Writing to this register is not recommended as this operation is used for factory testing.

Interrupt Identification Register

The ACE has an on-chip interrupt capability that allows for flexibility in interfacing popular microprocessors presently available. In order to provide minimum software overhead during data character transfers, the ACE prioritizes interrupts into four levels. The four levels of interrupt conditions are as follows: Receiver Line Status (priority 1); Received Data Ready (priority 2); Transmitter Holding Register Empty (priority 3); and Modem Status (priority 4).

Information indicating that a prioritized interrupt is pending and the type of that interrupt are stored in the Interrupt Identification Register (IIR). When addressed during chip-select time, the IIR freezes the highest priority interrupt pending and no other interrupts are acknowledged until the particular interrupt is serviced by the CPU. The contents of the IIR are indicated in Table 3 and are described below.

Bit 0: This bit can be used in either a hardwired prioritized or polled environment to indicate whether an interrupt is pending. When bit 0 is a logic 0, an interrupt is pending and the IIR contents may be used as a pointer to the appropriate interrupt service routine. When bit 0 is a logic 1, no interrupt is pending and polling (if used) continues.

Bits 1 and 2: These two bits of the IIR are used to identify the highest priority interrupt pending as indicated in Table 5.

Bits 3 through 7: These five bits of the IIR are always logic 0.

Interrupt Enable Register

This 8-bit register enables the four types of interrupts of the ACE to separately activate the chip interrupt (INTRPT) output signal. It is possible to totally disable the interrupt system by resetting bits 0 through 3 of the Interrupt Enable Register. Similarly, by setting the appropriate bits of this register to a logic 1, selected interrupts can be enabled. Disabling the interrupt system inhibits the Interrupt Identification Register and the active (high) INTRPT output from the chip. All other system functions operate in their normal manner, including the setting of the Line Status and MODEM Status Registers. The contents of the Interrupt Enable Register are indicated in Table 3 and are described below.

Bit 0: This bit enables the Received Data Available Interrupt when set to logic 1.

Bit 1: This bit enables the Transmitter Holding Register Empty Interrupt when set to logic 1.

Bits 2: This bit enables the Receiver Line Status Interrupt when set to logic 1.

Bit 3: This bit enables the MODEM Status Interrupt when set to logic 1.

Bits 4 through 7: These four bits are always logic 0.

MODEM Control Register

This 8-bit register controls the interface with the MODEM or data set (or a peripheral device emulating a MODEM). The contents of the MODEM Control Register are indicated in Table 3 and are described below.

Bit 0: This bit controls the Data Terminal Ready ($\overline{\text{DTR}}$) output. When bit 0 is set to logic 1, the $\overline{\text{DTR}}$ output is forced to a logic 0. When bit 0 is reset to a logic 0, the $\overline{\text{DTR}}$ output is forced to a logic 1. The $\overline{\text{DTR}}$ output of the ACE may be applied to an EIA inverting line driver (such as the DS1488) to obtain the proper polarity input at the succeeding MODEM or data set.

Bit 1: This bit controls the Request to Send ($\overline{\text{RTS}}$) output. Bit 1 affects the $\overline{\text{RTS}}$ output in a manner identical to that described above for bit 0.

Bit 2: This bit controls the Output 1 ($\overline{\text{OUT 1}}$) signal, which is an auxiliary user-designated output. Bit 2 affects the $\overline{\text{OUT 1}}$ output in a manner identical to that described above for bit 0.

Bit 3: This bit controls the Output 2 ($\overline{\text{OUT 2}}$) signal, which is an auxiliary user-designated output. Bit 3 affects the $\overline{\text{OUT 2}}$ output in a manner identical to that described above for bit 0.

Bit 4: This bit provides a local loopback feature for diagnostic testing of the ACE. When bit 4 is set to logic 1, the following occurs: the transmitter Serial Output (SOUT) is set to the Marking (logic 1) state; the receiver Serial Input (SIN) is disconnected; the output of the Transmitter Shift Register is "looped back" into the Receiver Shift Register input; the four MODEM Control inputs ($\overline{\text{CTS}}$, $\overline{\text{DSR}}$, $\overline{\text{DCD}}$, and $\overline{\text{RI}}$) are disconnected; and the four MODEM Control outputs ($\overline{\text{DTR}}$, $\overline{\text{RTS}}$, $\overline{\text{OUT 1}}$, and $\overline{\text{OUT 2}}$) are internally connected to the four MODEM Control inputs, and the MODEM Control output pins are forced to their inactive state (high). In the diagnostic mode, data that is transmitted is immediately received. This feature allows the processor to verify the transmit-and received-data paths of the ACE.

In the diagnostic mode, the receiver and transmitter interrupts are fully operational. The MODEM Control Interrupts are also operational, but the interrupts' sources are

I/O And
Peripherals



T-75-37-05
UM82450

now, the lower four bits of the MODEM Control Register instead of the four MODEM Control inputs. The interrupts are still controlled by the Interrupt Enable Register.

Bit 5 through 7: These bits are permanently set to logic 0.

MODEM Status Register

This 8-bit register provides the current state of the control lines from the MODEM (or peripheral device) to the CPU. In addition to this current-state information, four bits of the MODEM Status Register provide change information. These bits are set to a logic 1 whenever a control input from the MODEM changes state. They are reset to logic 0 whenever the CPU reads the MODEM Status Register.

Accessible Registers

The contents of the MODEM Status Register are indicated in Table 3 and are described below.

Bit 0: This bit is the Delta Clear to Send (DCTS) indicator. Bit 0 indicates that the \overline{CTS} input to the chip has changed state since the last time it was read by the CPU.

Bit 1: This bit is the Delta Data Set Ready (DDSR) indicator. Bit 1 indicates that the \overline{DSR} input to the Chip has changed state since the last time it was read by the CPU.

Bit 2: This bit is the Trailing Edge of Ring Indicator

(TERI) detector. Bit 2 indicates that the \overline{RI} input to the chip has changed from a low to a high state.

Bit 3: This bit is the Delta Data Carrier Detect (DDCD) indicator. Bit 3 indicates that the \overline{DCD} input to the chip has changed state. Whenever bits 0, 1, 2; or 3 are set to logic 1, a MODEM Status Interrupt is generated.

Bit 4: This bit is the complement of the Clear to Send (\overline{CTS}) input. If bit 4 (loop) of the MCR is set to a 1, this bit is equivalent to RTS in the MCR.

Bit 5: This bit is the complement of the Data-Set Ready (\overline{DSR}) input. If bit 4 of the MCR is set to a 1, this bit is equivalent to DTR in the MCR.

Bit 6: This bit is the complement of the Ring Indicator (\overline{RI}) input. If bit 4 of the MCR is set to a 1, this bit is equivalent to OUT 1 in the MCR.

Bit 7: This bit is the complement of the Data Carrier Detect (\overline{DCD}) input. If bit 4 of the MCR is set to a 1, this bit is equivalent to OUT 2 of the MCR.

Scratchpad Register

This 8-bit Read/Write Register does not control the ACE in any way. It is intended as a scratchpad register to be used by the programmer to hold data temporarily.

Typical Application

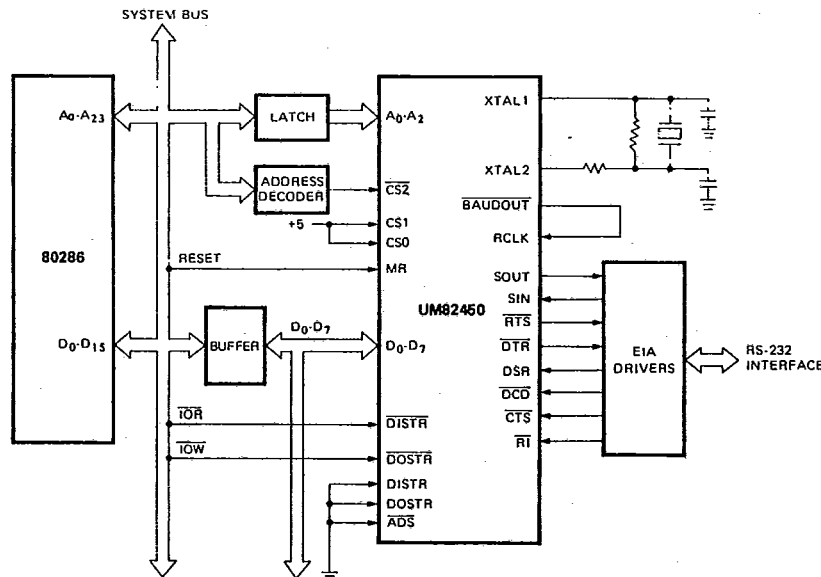



T-75-37-05

UM82450

Ordering Information

Part No.	Package
UM82450	40L DIP
UM82450L	44L PLCC

